



Operation Manual
For
Sodir
½ Size Convection Oven— FC-60, FC-60G



765 Westminster Street • Providence, Rhode Island 02903 • U.S.A.
Tel: (401) 273-3300 Fax: (401) 273-3328
www.equipex.com e-mail: service@equipex.com





IMPORTANT SAFEGUARDS

When using electrical appliances, basic safety precautions should always be followed, including the following:

1. Read all the instructions before use.
2. Do not touch hot surfaces; use handles or knobs.
3. To avoid electric shock, **do not immerse the power cord, or any part of the unit**, in any liquid.
4. Close supervision is necessary when any appliance is used, especially around children.
5. Unplug appliance from the electrical outlet when not in use, and before cleaning. Allow appliance to cool before installing or removing any parts or accessories, and before cleaning.
6. Do not operate any appliance with a damaged cord or plug, or if appliance should sustain damage, or malfunction in any way. In this event, return appliance to the nearest authorized service facility for examination, repair or adjustment.
7. The use of accessories and/or attachments not recommended by the appliance manufacturer may cause injury or damage to the appliance, and may void your warranty.
8. Do not use outdoors.
9. Do not allow the power cord to hang over the edge of a table or counter, or to be exposed to hot surfaces, as damage may occur.
10. Do not place appliance on or near a burner, or in a heated oven.
11. To disconnect an appliance, **first** turn all controls to the 'off' position; *then* unplug the power cord from the wall outlet.
12. Do not use appliance other than for its intended use.
13. SAVE THESE INSTRUCTIONS FOR LATER USE!

INTRODUCTION

The **SODIR** model FC-60 and FC-60 G convection ovens are designed to offer quality baking, cooking and reheating. The ovens are constructed of food service quality stainless steel, and are equipped with a rear-mounted blower fan and heating element, and, in the case of the FC-60 G, top mounted infrared quartz heating elements for salamander style finishing. The units are thermostatically controlled up to 480 F, with a 120-minute timer and constant on position. Two indicator lights, green and orange, (three for FC-60 G) add convenience for the operator. Units include four wire-baking racks. All models will accommodate up to four 1/2-size sheet pans or two 1/3-size cafeteria pans.

Specifications:

Model Configuration	Electrical	Plug
FC-60	208/240V, 1 PH, 3.3KW, 13/15A	NEMA-6-20P
FC-60/1	120V, 1PH, 1.7KW, 14A	NEMA-5-15P
FC-60 G	208/240V, 1PH, 3.3KW, 13/15A	NEMA-6-20P
FC-60 G/1	120V, 1PH, 1.7KW, 14A	NEMA-5-15P

INSTALLATION

The **SODIR** convection oven needs to be connected to a grounded outlet of proper voltage, 208/240V or 120V, depending on the model. DO NOT place the unit in a damp area or near steam sources. Make sure that the exterior rear ventilation panel is not blocked. Maintain 4" clearance at each side, rear and top of the oven.

ASSEMBLY

The SODIR convection comes from the factory assembled, but with the 4" adjustable legs removed for shipping. It is shipped with plastic exterior protective film, which must be removed before operation. DO NOT operate the oven prior to installing the 4" legs and protective film completely.

OPERATION

Preheating

To preheat the convection oven, select the desired temperature by rotating the thermostat knob clockwise to the desired temperature setting and then turn the timer knob, that also acts as an ON/OFF switch, clockwise to the maximum setting (120 minutes), or counterclockwise to the constant on position. The FC-60 G has a third knob for mode selection, convection mode for normal cooking, quartz infrared top heaters for salamander type operations or fan only for cool-down mode. Both indicator lights (green and orange) will be lit. The orange light will stay on until the oven reaches the desired temperature, and then cycle on and off. The green light will stay on until the timer expires. Allow about 20 minutes for the preheating process.

Cooking

After the preheat process is completed, select the desired temperature (unless it is already set) and turn the timer knob to select the time setting. When the set time is elapsed, the heating element and the blower fan will be switched off and the indicator lights will go out. The timer bell will chime repetitively, announcing the end of the cycle, until the timer button is pressed in to silence it. To use the oven in continuous mode, turn the timer knob counterclockwise to the position marked by the hand pictograph.

The SODIR convection ovens can be used for a wide variety of foods. Cooking times will vary depending on food products, temperature settings and desired results.

Cleaning

WARNING: Disconnect (unplug) electrical power supply before cleaning

Cleaning is very important in maintaining a safe and well working machine. Allow the oven to cool before cleaning. Remove the baking racks and clean them separately using a damp cloth or sponge and mild liquid soap. Use a cloth dampened slightly with a soap and water mixture to clean all exterior and interior stainless steel surfaces. Use a clean lint-free cloth to remove the excess water or soap. Make sure no water enters the unit through ventilation holes.

DO NOT use an abrasive sponge on exterior or interior surfaces

DO NOT wash the oven under running water

DO NOT spray the exterior motor housing with any liquid

DO NOT allow water to drip into the motor housing or onto electrical components

OVEN DOOR REMOVAL

The Sodir Models FC-60, FC-60/1, FC-60G and FC-60G\1 are equipped with a double glass door which is easily removable for cleaning. For cleaning, remove the door following the steps below:

1. Open the door completely



2. Apply gentle downward pressure on the top of the door while moving each hinge lock to “UP” position, engaging the “J” hook of the long arm (one lock per hinge)



3. Tilt the door up at a 45-60 degree angle (hinge lever arm will be released)



4. Pull the door out of the hinge slot



*NOTE: What hinge looks like in the open position.



Upon removal, the door can be washed or cleaned, both on the inside and on the outside

OVEN DOOR INSTALLATION

1. Insure that the notch on the bottom of the hinge fits onto the lip in the opening of the oven frame



2. Move the hinge lock to the “down” position to restore proper hinge operation

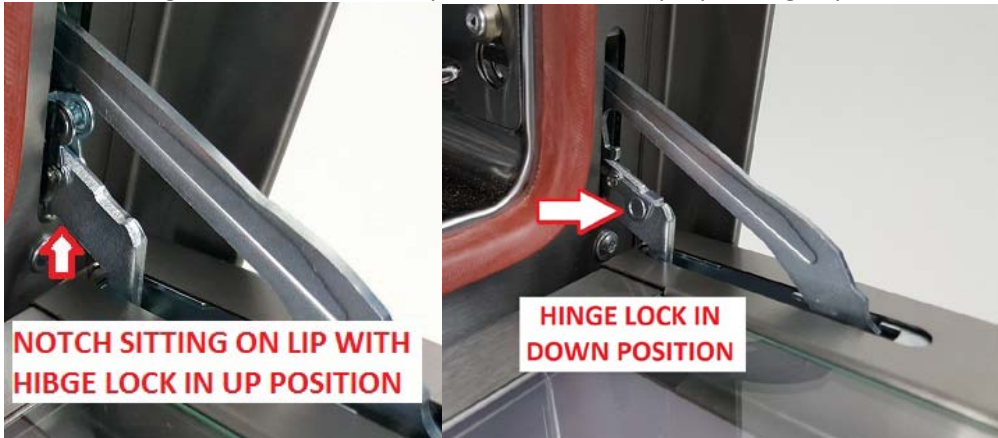

3. Do NOT leave the Hinge lock in the “UP” position at the end of installation

NOTE: Incorrect hinge installation positions



OVEN DOOR INSTALLATION COMPLETE

NOTE: Door should be level at the top edge to verify it has been installed properly



Maintenance

You should inspect all parts on a regular basis to ensure that all is in proper working order. If a part is damaged, have the unit repaired by an authorized service agency prior to returning the unit to operation. If you have trouble locating a service agency in your area, please consult our website at <http://www.equipex.com/>, or call us at 1-800-649-7885 and ask for customer service.

Spare Parts FC-60 and FC60/1

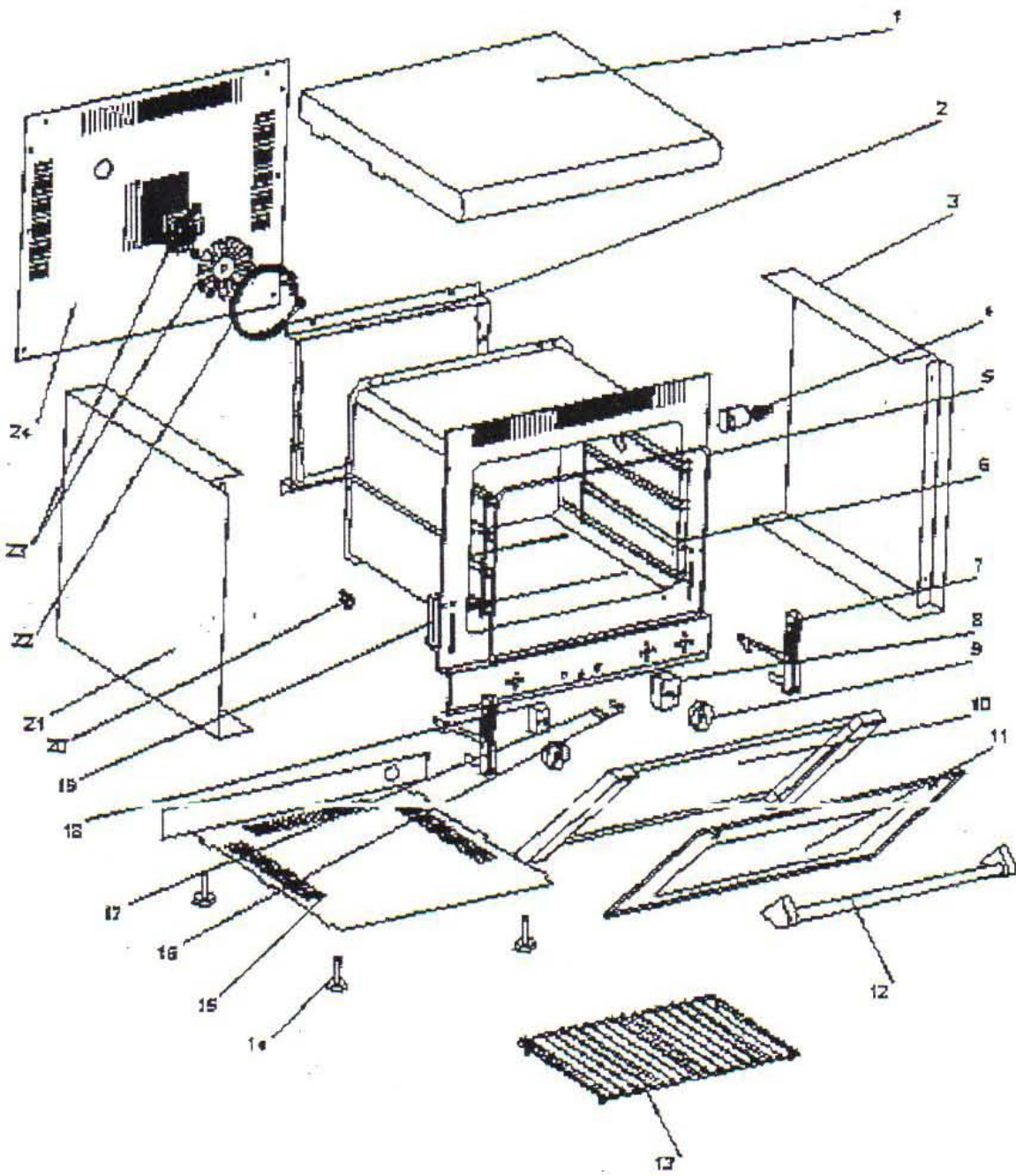

DWG #	Part #	QTY	Description
1	15124 308	1	Top casing
2	15111 108	1	Ventilation Cover
3	15016 308DR	1	Right side panel
4	A18022	1	Lamp with fixture 220V
4	A18021	1	Lamp with fixture 120V
5	H03005	1	Door Gasket
6	F01039	2	Shelf Rail
7	B09005	2	Door Hinge
8	A02028	1	120min timer with bell
9	A14078	2	Knob
10	H01012	1	Interior Glass
11	H01011	1	Exterior Glass
12	A15010	1	Handle
13	F01035	4	Wire Shelf
14	A13005	4	Leg
15	15017G010	1	Bottom Panel
16	A08009	1	Green Pilot Light 220 V
16	A08007	1	Green Pilot Light 120 V
17	A08003	1	Orange Pilot Light 220 V
17	A08004	1	Orange Pilot Light 120 V
18	A06042	1	Regulating Thermostat
19	B09007	2	Hinge support
20	A06035/1	1	Hi-limit thermostat
21	15016 308GA	1	Left Side Panel
22	D02034	1	Heating element 220V
22	D02041	1	Heating element 120V
23	A03001	1	Motor 220V
23	A03003	1	Motor 120V
24	15018G010	1	Back Cover
	Light Cover	1	Light Cover
	OEM60L1	1	120V Lamp
	OEM60L2	1	220V Lamp
	H0FC60DC	1	Door Complete
	A16013	1	Terminal Block, 3 Position
	90021	4	Baking Pan (25 7/8" x 17 7/8")

Spare Parts FC-60 G and FC60 G/1

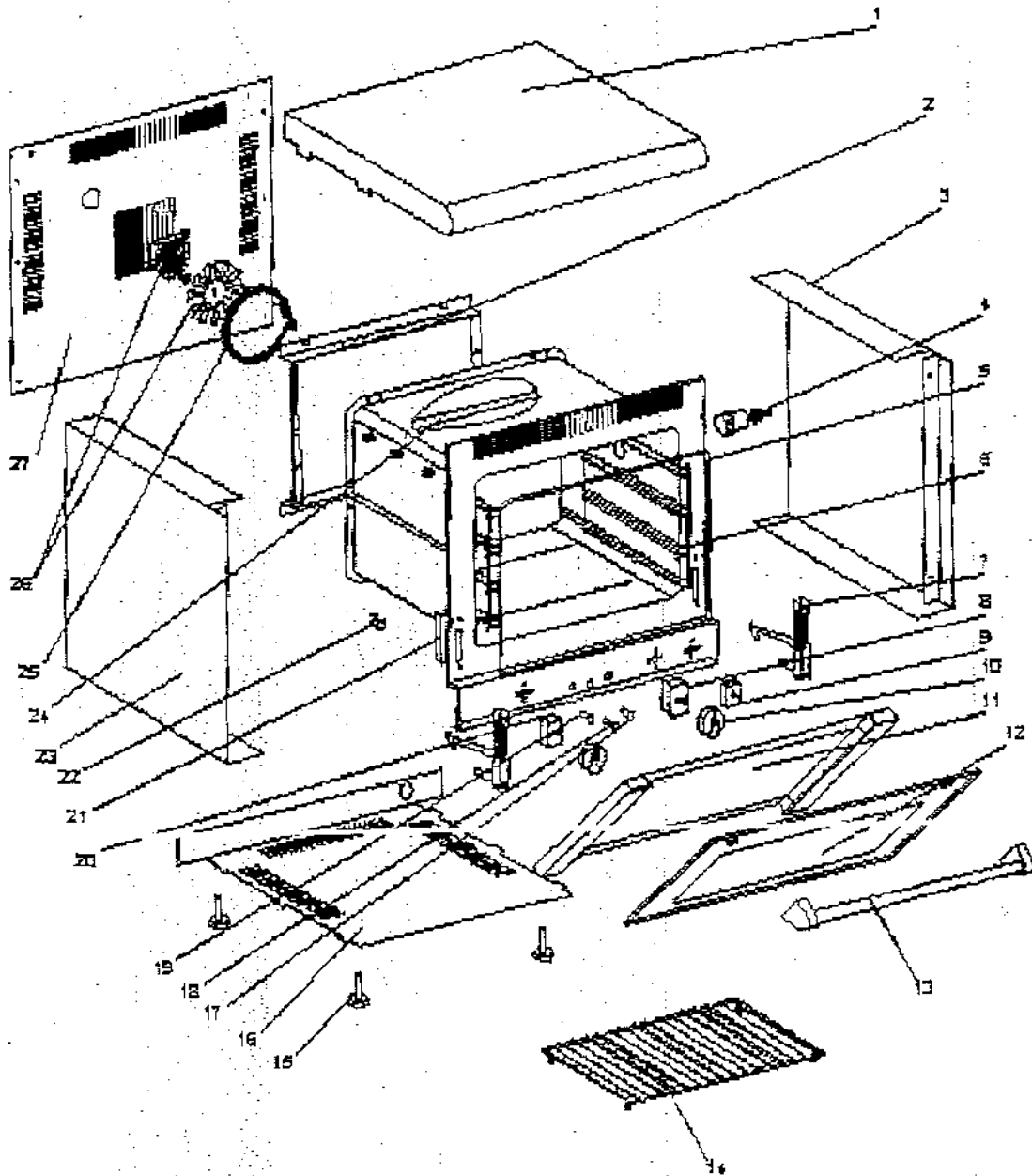

DWG #	Part #	QTY	Description
1	15124 308	1	Top casing
2	15111 108	1	Ventilation Cover
3	15016 308DR	1	Right side panel
4	A18022	1	Lamp with fixture 220V
4	A18021	1	Lamp with fixture 120V
5	H03005	1	Door Gasket
6	F01039	2	Shelf Rail
7	B09005	2	Door Hinge
8	A02028	1	120min timer with bell
9	A01014	1	Mode Switch
10	A14078	2	Knob
11	H01012	1	Interior Glass
12	H01011	1	Exterior Glass
13	A15010	1	Handle
14	F01035	4	Wire Shelf
15	A13005	4	Leg
16	15017G010	1	Bottom Panel
17	A08009	1	Green Pilot Light 220 V
17	A08007	1	Green Pilot Light 120 V
18/19	A08003	1	Orange Pilot Light 220 V
18/19	A08004	1	Orange Pilot Light 120 V
20	A06042	1	Regulating Thermostat
21	B09007	2	Hinge support
22	A06035/1	1	Hi-limit thermostat
23	15016 308GA	1	Left Side Panel
24	D04016	3	Quartz Tube
25	D02034	1	Heating element 220V
25	D02041	1	Heating element 120V
26	A03001	1	Motor 220V
26	A03003	1	Motor 120V
27	15018G010	1	Back Cover
28	D04028	3	IR Quartz with Element 220V
28	D01031	3	IR Heating Element 120V
	A09001	6	Ceramic Insulator for IR
	OEM60L1	1	120V Lamp
	OEM60L2	1	220V Lamp
	A16013	1	Terminal Block, 3 Position
	H0FC60DC	1	Door Complete
	90021	4	Baking Pan (25 7/8" x 17 7/8")



LIMITED WARRANTY

Your new **EQUIPEX** product is warranted to the original purchaser for a period of one year from the date of purchase.

This limited warranty is against defects from original factory imperfections in material and/or workmanship and includes labor for replacement of defective parts, provided repairs are performed by an authorized service agency. Our obligation under this warranty is limited to repairing or replacing any part or parts thereof. The CUSTOMER must inform the Service Agency of warranty coverage and provide a copy of the dated sales or delivery receipt BEFORE WARRANTY REPAIRS BEGIN. Replacement parts and accessories are warranted for ninety (90) days from the date of purchase when purchased separately and will be verified by dated sales receipt or packing slip for that item. All parts or accessories replaced under warranty must be returned to the Service Agency.

This warranty applies only to equipment under normal use and service in the U.S.A. and Canada. It does not apply to any item which has been repaired or altered in any way so as, in the judgment of EQUIPEX, to affect its reliability.

THE FOLLOWING ARE NOT COVERED UNDER WARRANTY:

1. Damage caused by abuse, misuse or dropping or other similar incidental damage caused by, or as a result of, customer failure to follow assembly, operation, cleaning, user maintenance or storage instructions.
2. Labor to replace inoperative parts such as bulbs, plugs or racks due to normal wear and tear or abuse.
3. Materials or labor to repair scratched, stained, chipped, pitted, dented or discolored surfaces, attachments or accessories.
4. Transportation charges to or from a service agency for repair of your machine. If you should have questions relating to this issue, please call **Equipex** at 1-800-649-7885.
5. Labor charges to install or test attachments or accessories, which are replaced for any reason.
6. SHIPPING DAMAGES. Visible and hidden damages are the responsibility of the freight carrier. The consignee must file the claim promptly against the carrier. KEEP ALL ORIGINAL CONTAINERS AND PACKAGING MATERIAL FOR CARRIER INSPECTION.
7. Products placed or stored in the equipment are not subject to this warranty and no responsibility is assumed thereof.

THIS WARRANTY IS GIVEN EXPRESSLY AND IN LIEU OF ALL OTHER WARRANTIES, EXPRESSED OR IMPLIED, FOR MERCHANTABILITY AND FOR FITNESS TOWARD A PARTICULAR PURPOSE AND CONSTITUTES THE ONLY WARRANTY MADE BY EQUIPEX, LLC. IT NEITHER ASSUMES, NOR AUTHORIZES ANY PERSON TO ASSUME FOR US, ANY OTHER LIABILITY IN CONNECTION WITH THE SALE OF THE SUBJECT EQUIPMENT.

For service, please call **EQUIPEX** at 1-800-649-7885, menu option # 3

765 Westminster Street • Providence, Rhode Island 02903 • U.S.A.
Tel: (401) 273-3300 Fax: (401) 273-3328
www.equipex.com e-mail: service@equipex.com