

THOMSON™

Chest Freezer



User Manual

TFRF520-D-SM



WARNING: Read all of the instructions before using this appliance. When using this appliance, always exercise basic safety precautions, including the following:

NOTE: If the freezer has been placed in a horizontal or tilted position for any period of time wait 24 hours before plugging the unit in.

1. Use this appliance only for its intended purpose as described in this use and care guide.
2. This freezer must be properly installed in accordance with the installation instructions before it is used. See grounding instructions in the installation section.
3. Never unplug your freezer by pulling on the power cord. Always grasp the plug firmly and pull straight out from the outlet.
4. Repair or replace immediately, all electric service cords that have become frayed or otherwise damaged. Do not use a cord that shows cracks or abrasion damage along its length, the plug or the connector end.
5. Unplug your freezer before cleaning or before making any repairs.
Note: If for any reason this product requires service, we strongly recommend that a certified technician performs the service.
6. Do not use any electrical device or any sharp instrument in defrosting your freezer.
7. If your old freezer is not being used, we recommend that you remove the doors. This will reduce the possibility of danger to children.



WARNING: After your freezer is in operation, do not touch the cold surfaces in the freezer compartment, particularly when hands are damp or wet. Skin may adhere to these extremely cold surfaces.

9. Do not refreeze foods, which have been thawed completely. The United States Department of Agriculture in Home and Garden Bulletin No. 69 reads: "...You may safely refreeze frozen foods that have thawed if they still contain ice crystals or if they are still cold-below 40°F".

"...Thawed ground meats, poultry, or fish that have any off-odor or off-color should not be refrozen and should not be eaten. Thawed ice cream should be discarded. If the odor or color of any food is poor or questionable, discard it. The food may be dangerous to eat."

“...Even partial thawing and re-freezing reduce the eating quality of foods, particularly fruits, vegetables, and prepared foods. The eating quality of red meats is affected less than that of many other foods. Use refrozen foods as soon as possible, to save as much of its eating quality as you can.

10. This freezer should not be recessed or built-in an enclosed cabinet. It is designed for freestanding installation only.
11. Do not operate your freezer in the presence of explosive fumes.

THOMSON™

SAVE THESE INSTRUCTIONS



DANGER

Risk of child entrapment. Before you throw away your old refrigerator or freezer, take off the doors. Leave the shelves in place so that children may not easily climb inside.

This appliance is not intended for use by persons (including children) with reduced physical, sensory or mental capabilities, or lack of experience and knowledge, unless they have been given supervision or instruction concerning use of the appliance by a person responsible for their safety.

Children should be supervised to ensure that they do not play with the appliance.

Do not use extension cords or ungrounded (two prong) adapters.

If the supply cord is damaged, it must be replaced by the manufacturer, its service agent or similar qualified person in order to avoid hazard.

WARNING: Keep ventilation openings, in the appliance enclosure or in the built-in structure, clear of obstruction.

WARNING: Do not use mechanical devices or other means to accelerate the defrosting process, other than those recommended by the manufacturer.

WARNING: Do not damage the refrigerant circuit.

WARNING: Do not use electrical appliances inside the food storage compartments of the appliance, unless they are of the type recommended by the manufacturer.

This appliance is intended to be used in household and similar applications such as

- staff kitchen areas in shops, offices and other working environments;
- farm houses and by clients in hotels, motels and other residential type environments;
- bed and breakfast type environments;
- catering and similar non-retail applications.

Staple your receipt to your manual.

You will need it to obtain warranty service.

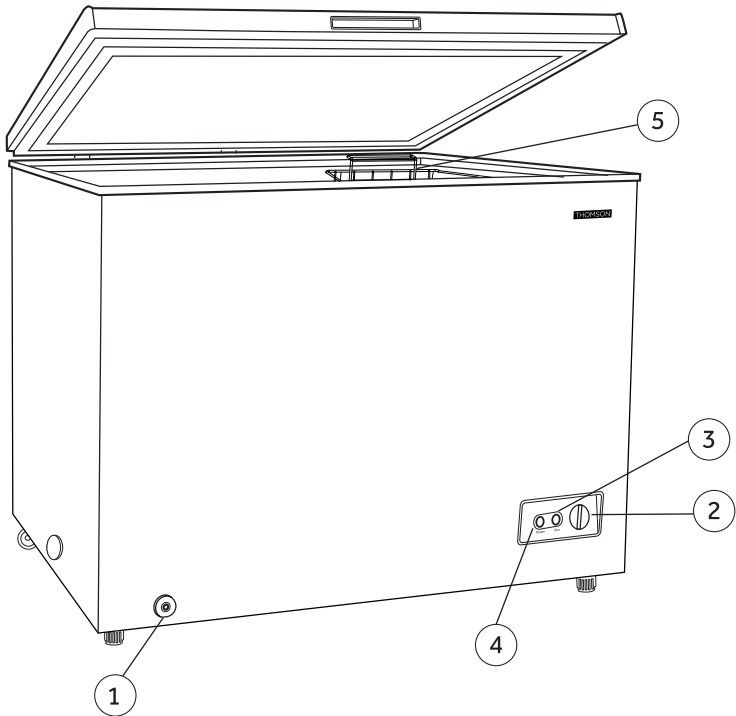

1. Exterior Drain Plug
2. Temperature Control
3. Compressor On Indicator
4. Power on Indicator
5. Vinyl Coated Wire Basket

Unpacking Your Freezer

1. Remove all packaging material. This includes the foam base and all adhesive tape holding the freezer accessories inside and outside.
2. Inspect and remove any remains of packing, tape or printed materials before powering on the freezer.

Adjusting Your Freezer

- Your freezer is designed for freestanding installation only. It should not be recessed or built-in.
- Place the freezer on a floor strong enough to support it fully loaded.
- When moving the freezer, never tilt it more than a 45-degree angle. This could damage the compressor and the sealed system.
- If the freezer is tilted let it stand in an upright position for at least 24 hours prior to plugging. This is to allow the refrigerant to settle.

Proper Air Circulation

- To assure your freezer works at the maximum efficiency it was designed for, you should install it in a location where there is proper air circulation, plumbing and electrical connections.
- The following are recommended clearances around the freezer:
 - Sides 4" (102mm)
 - Back 4" (102mm)
 - Top Do not block



WARNING: ELECTRICAL REQUIREMENT - SHOCK HAZARD

Electrical Requirement

- Make sure there is a suitable power Outlet (115 volts, 15 amps outlet) with proper grounding to power the freezer.
- Avoid the use of three plug adapters or cutting off the third grounding in order to accommodate a two plug outlet. This is a dangerous practice since it provides no effective grounding for the freezer and may result in shock hazard.

Install Limitations

- Do not install your freezer in any location not properly insulated or heated e.g. garage etc. Your freezer was not designed to operate in temperature settings below 55° Fahrenheit.
- Select a suitable location for the freezer on a hard even surface away from direct sunlight or heat source e.g. radiators, baseboard heaters, cooking appliances etc. Any floor unevenness should be corrected.

Operating Your Freezer

- Once the freezer is in its proper place, plug it in an electrical outlet having 115 volts and 15 amps.
- Set the temperature, on the temperature control knob. "1" being the warmest and "7" being the coldest. Initially set the temperature on "4". Place food inside the freezer. After using the freezer for 24 hours set the freezer to your desired setting.
- In case you unplug your freezer or experience an electrical outage, allow 5 minutes before plugging it back in.

General Features

Adjustable temperature dial: (see fig. # 1)

The temperature of the appliance is controlled by setting the thermostat dial on the front of the cabinet.

The number 1 indicates the warmest setting. The number 7 indicates the coldest setting.

The number 5 setting should be sufficient for regular home use.

To stop the cooling function, turn the dial to the "0" position.

The temperature inside the appliance can vary based on ambient room temperature, the frequency that the lid is opened and the amount of fresh food that has recently been added to the appliance.

Do not overload the appliance as this can affect performance.

Do not freeze large quantities of fresh food at the same time.

(Note: If the freezer has been placed in a horizontal or tilted position for any period of time wait 24 hours before plugging the unit in.)

fig. # 1

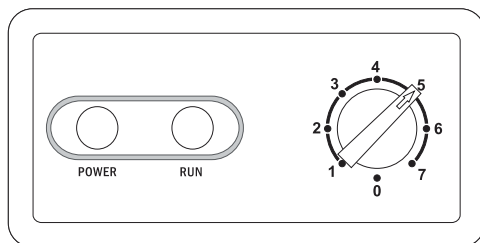

Normal Operating Sounds You May Hear

- Boiling water, gurgling sounds or slight vibrations that are the result of the refrigerant circulating through the cooling coils.
- The thermostat control will click when it cycles on and off.

Note: If the temperature control knob sets to 7, the compressor may run continuously. It's a quick-frozen mode. Please do not set to 7 frequently.

Food Storage Basket

- Your freezer has a basket. Removable basket allows you to store food more accessibly or you can remove it if not needed.

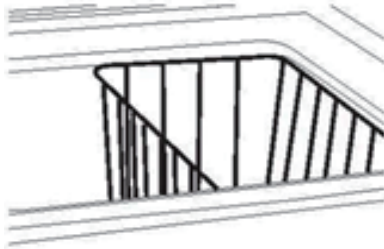

Defrosting and Draining

- For most efficient operation and minimum energy consumption, defrost whenever the frost becomes 1/4" thick. Never use a sharp or metallic instrument to remove the frost, as it may damage the cooling coils. (A punctured coil will void the warranty). Do not use boiling water as it may damage the unit. It is advisable to let ice and frost melt naturally.
- Remove frozen food from the freezer and place it in a cooler to protect the food.
- Unplug the unit. Defrosting usually takes a few hours. To defrost faster keep the freezer door open.
- For draining, place a tray beneath the outer drain plug. Unscrew and remove drain plug. This will let the water flow out in the tray. When done, screw on the drain plug in place.
Note: monitor the container under the drain to avoid overflow.
- When draining is complete, wipe the interior of the freezer with a soft cloth. Plug in power cord back into the electrical outlet.
- Reset the temperature control to the desired setting.
- Return the food into the freezer.

Food Storage Information

Frozen Food:

- Wipe containers before storing to avoid needless spills.
- Hot food should be allowed to cool before storing in the freezer.
This will prevent unnecessary energy use.
- When storing meats, keep in the original packaging or rewrap as necessary.
- Proper freezer storage requires correct packaging. All foods must be in packages, which do not allow the flow of air or moisture in, or out. Improper storage will result in odor and taste transfer and will result in the drying out of the improperly packaged food.
- Follow package or container instructions for proper storage.
- Packaging Recommendations:
 - Plastic containers with air tight lids
 - Heavy duty aluminum foil
 - Plastic wrap made from saran film
 - Self-sealing plastic bags
- Do not refreeze defrosted/thawed foods.
- It is recommended that the freezing date be marked on the packaging.

These are some suggestions for safe storage:

- | | |
|------------------------------------|---------------|
| • TV Dinners | 3 - 4 Months |
| • Fresh Shrimp, scallops, crawfish | 3 - 6 Months |
| • Hamburger & stew meats | 3 - 4 Months |
| • Ground Turkey, veal, pork | 3- 4 Months |
| • Chops | 4- 6 Months |
| • Steaks | 6 - 12 Months |
| • Chicken or turkey, whole | 1 year |

For detailed storage chart visit FDA website:

www.cfsan.fda.gov/~dms/fttstore.html

Cleaning and Maintenance



Warning: To avoid electric shock always unplug your freezer before cleaning. Ignoring this warning may result in death or injury.



Caution: Before using cleaning products, always read and follow manufacturer's instructions and warnings to avoid personal injury or product damage.

General:

- Prepare a cleaning solution of 3-4 tablespoons of baking soda mixed with warm water. Use sponge or soft cloth, dampened with the cleaning solution, to wipe down your freezer.
- Rinse with clean warm water and dry with a soft cloth.
- Do not use harsh chemicals, abrasives, ammonia, chlorine bleach, concentrated detergents, solvents or metal scouring pads. SOME of these chemicals may dissolve, damage and/or discolor your freezer.

Door Gaskets:

- Clean door gaskets every three months according to general instructions. Gaskets must be kept clean and pliable to assure a proper seal.
- Petroleum jelly applied lightly on the hinge side of gaskets will keep the gasket pliable and assure a good seal.

Disposal:

- This appliance may not be treated as regular household waste, it should be taken to the appropriate waste collection point for recycling of electrical components. For information on local waste collection points, contact your local waste removal agency or government office.
- Disposal of this appliance should be in accordance with federal and local regulations.

Power Interruptions

- Occasionally there may be power interruptions due to thunderstorms or other causes. Remove the power cord from AC outlet when a power outage occurs. When power has been restored, replug power cord to AC outlet. If outage is for a prolonged period, inspect and discard spoiled or thawed food in freezer. Clean freezer before reusing.

Vacation and Moving Care

- For long vacations or absences, empty food from freezer, unplug the unit and clean the door gaskets according to "General cleaning" section. Prop doors open, so air can circulate inside. When moving always move the freezer vertically. Do not move with the unit lying down. Possible damage to the sealed system could occur.



WARNING: IF OUTAGE IS FOR A PROLONGED PERIOD, INSPECT AND DISCARD SPOILED OR THAWED FOOD IN FREEZER. CLEAN FREEZER BEFORE REUSING.

Freezer Does Not Operate:

- Check if freezer is plugged in.
- Check if there is power at the ac outlet, by checking the circuit breaker.
- Wait for 30-40 minutes to see whether freezer will start. Compressor cycle must be complete to operate.

Food temperature appears too warm:

- Frequent door openings.
- Allow time for recently added warm food to reach freezer temperature.
- Check gaskets for proper seal.
- Adjust temperature control to colder setting.

Too much frost build-up inside unit:

- Make sure temperature control is not set to "ON" setting for extended period of time.

Food temperature is too cold:

- If temperature control setting is too cold, adjust to a warmer setting and allow several hours for temperature to adjust.

Compressor runs too frequently:

- This may be normal to maintain constant temperature during high temperature and humid days.
- Doors may have been opened frequently or for an extended period of time.
- Check gasket for proper seal.
- Check to see if doors are completely closed.
- Check freezer compartment for blockage from frozen food packages, containers, etc.

Freezer has an odor:

- Interior needs cleaning.
- Foods improperly wrapped or sealed are giving off odors.

For service assistance and product information, please call: 1-800-968-9853.

Pour obtenir assistance et information appelez: 1-800-968-9853.

Curtis International Ltd.

7045 BECKETT DRIVE, UNIT 15, MISSISSAUGA, ON, L5S 2A3 www.curtisint.com

PRODUCT SPECIFICATIONS

PRODUCT SPECIFICATIONS	
Model No.	TFRF520-D-SM
CAPACITY OF FREEZER IN CU FT	5.0
SHELF MATERIAL	WIRE
TEMPERATURE CONTROL TYPE	MANUAL DEFROST
TEMPERATURE RANGE IN FAHRENHEIT AND CELSIUS	-12 C to -24 C 10.4 F to 11.2 F
DEPTH (EXCLUDING HANDLES) (IN)	/
DEPTH (INCLUDING HANDLES) (IN)	/
DEPTH (LESS DOOR) (IN)	20-13/16"
DEPTH WITH DOOR OPEN 85 DEGREES (IN)	22-3/8"
HEIGHT TO TOP OF DOOR HINGE (IN.)	32-1/2"
PRODUCT DEPTH (IN.)	22-3/16"
PRODUCT HEIGHT (IN.)	33-1/4"
PRODUCT WIDTH (IN.)	29-11/16"

To make a warranty claim, do not return this product to the store. Please email support@curtiscs.com or call 1-800-968-9853.

1 Year Warranty

This product is warranted to be free from defects in material and workmanship for a period of one (1) year from the date of original purchase. During this period, your exclusive remedy is repair or replacement of this product or component found to be defective, at our option; however, you are responsible for all costs associated with returning the product to us. If the product or component is no longer available, we will replace with a similar one of equal or greater value. Prior to a replacement being sent, the product must be rendered inoperable or returned to us.

This warranty does **not** cover glass, filters, wear from normal use, use not in conformity with the printed directions, or damage to the product resulting from accident, alteration, abuse, or misuse. This warranty extends only to the original consumer purchaser or gift recipient. Keep the original sales receipt, as proof of purchase is required to make a warranty claim. This warranty is void if the product is used for other than single-family household use or subjected to any voltage and waveform other than as on the specified rating on the label (e.g., 115V~60Hz).

We exclude all claims for special, incidental, and consequential damages caused by breach of express or implied warranty. All liability is limited to the amount of the purchase price. **Every implied warranty, including any statutory warranty or condition of merchantability or fitness for a particular purpose, is disclaimed except to the extent prohibited by law, in which case such warranty or condition is limited to the duration of this written warranty.** This warranty gives you specific legal rights. You may have other legal rights that vary depending on where you live. Some states or provinces do not allow limitations on implied warranties or special, incidental, or consequential damages, so the foregoing limitations may not apply to you.

For faster service, locate the model, type, and serial numbers on your appliance.